

Vanne Passage Direct

Réf : 0121

ACIER - PN25 -

Brides

Tige extérieure

97/23/CE Catégorie III

ATEX

Ø	D	L	H	V	Ps	Pds	
	mm				bar	kgs	
8	1/4						
10	3/8						
15	1/2						
20	3/4						
25	1						
32	1 1/4						
40	1 1/2						
50	2	50	250	387	225	25	27,0
65	2 1/2	65	270	463	280	25	37,0
80	3	80	280	520	280	25	45,0
100	4	100	300	604	280	25	58,0
125	5	125	325	720	320	25	86,0
150	6	150	350	827	320	25	110,0
200	8	200	400	1035	360	25	178,0
250	10	250	450	1233	500	25	257,0
300	12	300	500	1435	650	25	362,0
350	14	350	550	1650	650	25	508,0
400	16	400	600	1845	720	25	693,0
450	18	450	650	1850	720	25	867,0
500	20	500	700	2330	800	25	1151
600	24	600	840	2745	800	25	1798

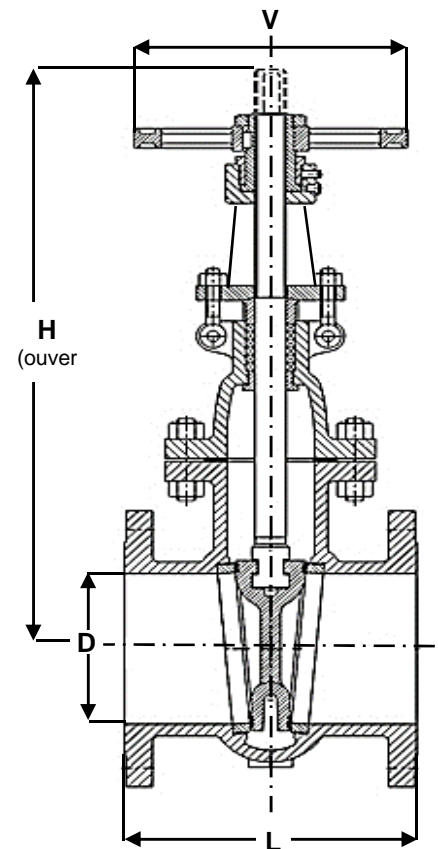

Conditions de service maximum / Maximum working conditions

Température max. /Max. temperature 400°C **Pression max. / max. pressure** 25B
(ATTENTION ne s'agissant pas d'une pression / température associées, elle peut être déterminée par nos soins)

Matières / Matériaux

CORPS / BODY Acier GSC 25
OPERCULE / WEDGE Acier GSC 25
TIGE / STEM Inox F6
SIEGES /SEAT Inox F6
P.ETOUPE / G.PACKING Graphite

Options / Options

