

Purgeur Bi Métallique

Réf : 0842 - 0843

ACIER - PN40 -

Brides

97/23/CE

Ø mm	L Brides	L BSP	H	Pds Kgs	
				Brides	BSP
8	1/4				
10	3/8				
15	1/2	150	122	150	4,50 3,30
20	3/4	150	122	150	4,90 3,20
25	1	150	145	167	6,30 4,00
32	1 1/4				
40	1 1/2				
50	2				
65	2 1/2				
80	3				
100	4				
125	5				
150	6				
200	8				
250	10				
300	12				
350	14				
400	16				
450	18				
500	20				
600	24				

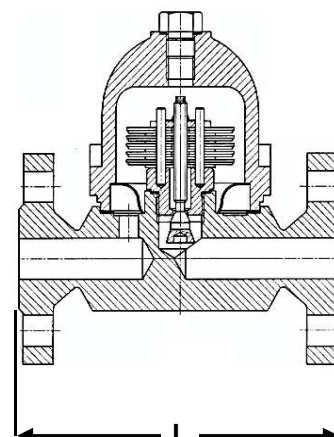
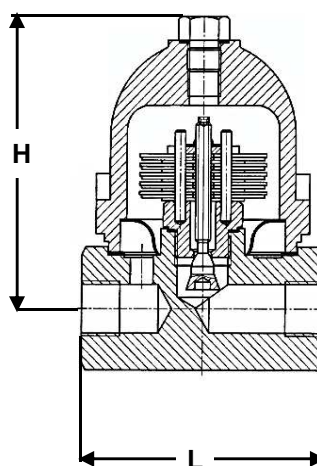

Conditions de service maximum / Maximum working conditions

Température max. /Max. temperature 400°C

Pression max. / max. pressure 22B

(ATTENTION ne s'agissant pas d'une pression / température associées, elle peut être déterminée par nos soins)

Matières / Matériaux

CORPS / BODY Acier
 CHAPEAU / BONNET Acier
 BI METALLIQUE / BI METALIC Inox 302
 SIEGE / SEAT Inox 304

Options / Options

